

Common Instructions to Candidates :

- 1) This is a question cum answer paper booklet.
 - 2) Space is provided to write answers below each question. Answer should be written within the space provided.
 - 3) This question paper has 5 questions including the matching type question.
 - 4) Candidate should not write the answer with pencil. Answer written with pencil will not be evaluated. (Except graphs, diagrams & maps).
 - 5) In case of multiple choice, fill in the blanks and matching questions, scratching, rewriting & marking is not allowed. Answers with such errors will not be evaluated.
1. a) Fill in the blanks with the correct word(s) by selecting from the choices given in the brackets. **[5 x 1 = 5]**
- i) Large size threads cut on a machine called _____
(lathe, shaper, drilling).
 - ii) Drawings of small instruments are drawn to _____
(full scale, reduced scale, enlarged scale).
 - iii) Head lamps of motor vehicles are in the shape of _____
(ellipse, hyperbola, parabola).
 - iv) Radial height of the gear tooth above the pitch circle is _____
(addendum, dedendum, module).
 - v) Knuckle threads are used in _____
(lead screw of lathe, coupler of railway carriages, screw of a bench-vice).

b) Match the following :

[5 x 1 = 5]

Group A

Group B

- | | |
|-------------|--|
| i) Crest. | a) distance between crest and root. |
| ii) Root. | b) equal to half the lead. |
| iii) Flank. | c) equal to lead. |
| iv) Slope. | d) surface between the crest and the root. |
| v) Depth. | e) inner most part of a thread. |
| | f) outer most part of a thread. |

2. a) Print the given word in single stroke inclined capital letters of height 18 mm with ratio 6 : 5.

“Inclined Letters”

- b) Draw a common external tangent to two unequal circles of radii 20 mm and 15 mm.

3. a) Construct a parabola in a parallelogram of sides 100 mm and 45 mm and with an included angle 75° .

- b) Draw the front view and top view of a square nut for 24 mm diameter bolt when its two faces are equally seen in the front view according to approximately standard dimensions.

4. Construct a diagonal scale of R.F 1 : 20 showing divisions of 0.01 m and capable of measuring 3 metre. Mark a distance of 2.37 metre on it.

OR

The pictorial view of an object is shown in Figure No. 1. Draw the following orthographic views and mark the dimensions.

- i) Front view. _____ looking in the direction of arrow "X".
- ii) Top view. _____ looking in the direction of arrow "Y".
- iii) Side view. _____ looking in the direction of arrow "Z".

5. Figure No. 2 shows the front view of a pinjoint or knuckle joint. Draw the same in full size (1 : 1 size).

Sectional elevation.

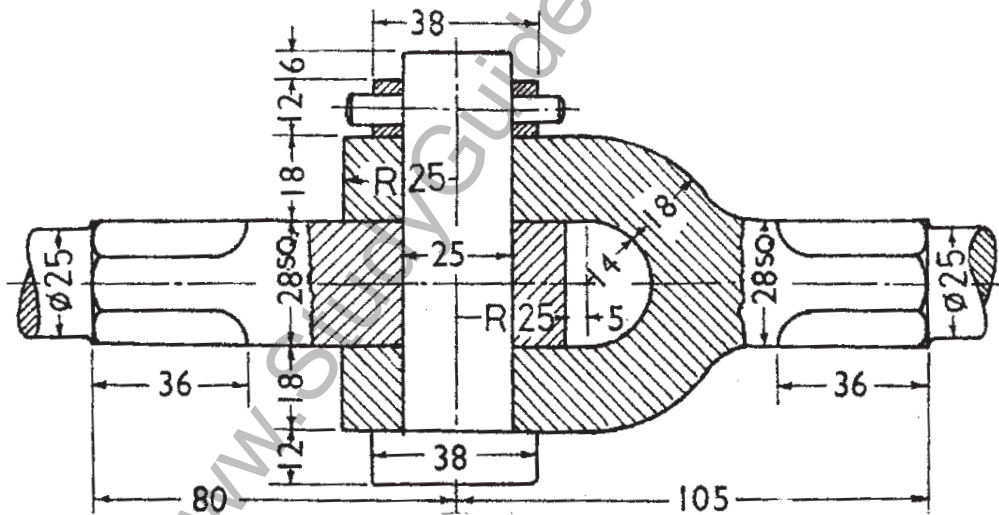

PIN-JOINT OR KNUCKLE JOINT

Figure NO 2